

UDK 621.791.75.

**V. Lebedev, ScD., V. Rymsha, ScD.,  
I. Lendel**

### **BLDC ELECTRIC-DRIVE IN THE MECHANISM OF PULSE FEED OF ELECTRODE WIRE**

***Abstract.** In this paper, the basic requirements for the electric-drive of mechanism of pulsed wire feed, and the benefits of using a special Brushless Direct Current electric-drive are described. For phase commutation of electric-drive applies a specially designed, half-bridge circuit to regulate the strength of the current phase of the stator windings. This allows increasing the speed braking, reduce energy consumption and reduce the surface temperature of the Brushless Direct Current drive.*

***Keywords:** welding, surfacing, feed mechanism, inertia, decelerating of BLDC electric drive, power consumption*

**В. А. Лебедев, В. В. Рымша, доктора техн. наук,  
И. В. Лендел**

### **ВЕНТИЛЬНЫЙ ЭЛЕКТРОПРИВОД В МЕХАНИЗМЕ ИМПУЛЬСНОЙ ПОДАЧИ ЭЛЕКТРОДНОЙ ПРОВОЛОКИ**

***Аннотация.** Сформулированы основные требования к приводу механизма импульсной подачи электродной проволоки, описано преимущества использования специального вентильного электропривода. Для коммутации фаз вентильного электропривода, применяется специально разработанная полумостовая схема, позволяющая регулировать ток фазных обмоток статора. Это позволяет достичь повышения скорости торможения, снизить потребление электроэнергии и температуру поверхности применяемого электропривода.*

***Ключевые слова:** сварка, наплавка, механизм подачи, инерция, коммутация фаз, потребление электроэнергии*

**В. О. Лебедев, В. В. Римша, доктори техн. наук,  
І. В. Лендел**

### **ВЕНТИЛЬНИЙ ЕЛЕКТРОПРИВОД В МЕХАНИЗМІ ІМПУЛЬСНОЇ ПОДАЧІ ЕЛЕКТРОДНОГО ДРОТУ**

***Анотація.** Сформульовані основні вимоги до приводу механізму імпульсної подачі електродного дроту, описано переваги використання спеціального вентильного електроприводу. Для комутації фаз вентильного електроприводу застосовується спеціально розроблена, напівмостова схема, що дозволяє регулювати струм фазних обмоток статора. Це дає можливість підвищити швидкість гальмування, знизити споживання електроенергії та температуру поверхні застосовуваного електроприводу.*

***Ключові слова:** зварювання, наплавлення, механізм подачі, інерція, комутація фаз, споживання електроенергії*

#### **Introduction**

The drive composed of a collector DC electric motor and worm reduction gear has been the most widely used in semi-automatic and automatic welding and surfacing in shielding gases and wire feed at a constant rate. Experience of application of such machines as a drive in organizing the pulse electrode wire feed (PEWF) has a negative result.

**The requirements for the mechanism of pulse electrode wire feed (MPEWF).**

**The advantages of electric drive with Brushless Direct Current electric motor (BLDC motor).**

The works [1 – 7] show that to provide the controlled electrode metal transfer and improve the complex of service characteristics, MPEWF drive must meet the following requirements:

1. Adjust the pulse feed frequency in the range of not less than 1 – 60 Hz [2].
2. Regulate the pulse feed pitch in the range of not less than 0,5 – 3 mm [8, 9].
3. Regulate PEWF pulse duty factor of not less than 2 times [2].
4. Provide repeatability of feed pitch value.
5. Possess low weight and size characteristics.

After making the review of the possible variants of drives for the realization of pulse electrode wire feed and taking into account the requirements for service characteristics of such type of drive, the BLDC motor was selected,

which is one of the most challenging types of drives for today [10].

According to [11, 12], BLDC motor has the following advantages:

- Simple design.
- High maintainability.
- Absence of mechanical commutator.
- High weight and size characteristics.
- High reliability.
- High efficiency factor in a wide range of rotation frequencies.
- Electronic control of electrical and mechanical characteristics, mode of operation, and etc.

**Block diagram and deceleration mode of BLDC electric drive.**

In Ukraine in designing and manufacture of BLDC electric drives the PJSC “Plant of Electrical Equipment” (Nikolayev) is involved. Together with the specialists of this enterprise, taking BLDC drive VREP-57-0,05 as a prototype, the drive “Impulse 2 PM -80” was designed and manufactured for organizing of PEWF.

As compared to the prototype BLDC drive VREP-57-0,05 the drive “Impulse 2 PM-80” is characterized by improved dynamic characteristics, the new special software and interface.

Like the prototype, the designed BLDC motor combines electromechanical transducer (EMT) with passive gear rotor, salient pole stator and concentrated coils of its windings, which by means of electronic control circuit (ECC) generally composed of transistor inverter, speed and current controllers and distributor of pulses on phases and other devices, is connected to DC voltage source (VS) (Fig. 1).

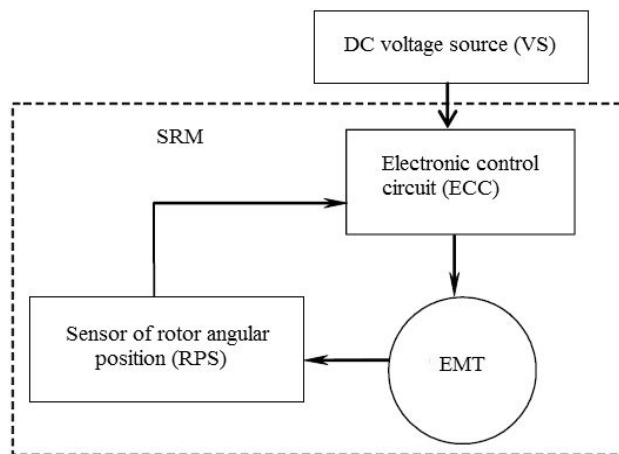

Fig. 1. Block diagram of BLDC electric drive

Basing on the specifics of MPEWF drive, the main operation mode of BLDC motor is intermittent one. Obtaining the necessary inertia force of electrode metal drop predetermines dynamic characteristics of the motor. The value of inertia force of the drop depends to a greater extent on the rate of deceleration of the electrode wire; therefore, the achieving of the minimum deceleration time is one of the key stages in designing BLDC electric drive for MPEWF.

The realization of maximum deceleration rate is connected with a need in organizing the magnetic biasing of magnetic system and maintaining of decelerating current phase.

The deceleration of BLDC motor is realized during exciting of phase at the area of decreasing of magnetic conductivity  $\lambda$  (Fig. 2), i.e. when the rotor rotates in the direction of mismatched position of poles of stator and rotor. When the current  $i_t$  is passing through the phase at  $\Theta_{tor}$  area (Fig. 2) the negative electromagnetic moment is created, the value of which, and hence the intensity of deceleration depend on the value of current  $i_t$  [13].

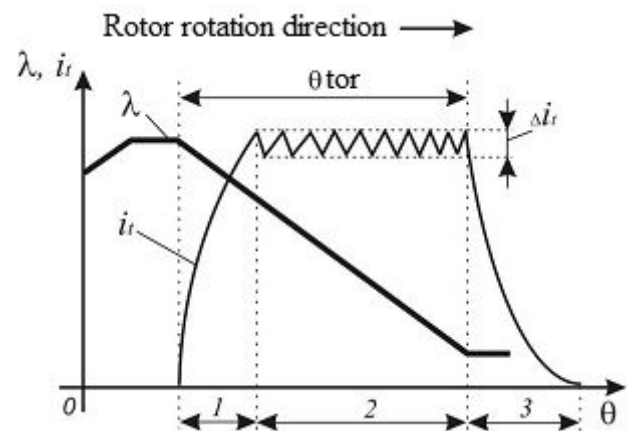

Fig. 2. Phase current in deceleration of BLDC motor

For commutation of BLDC motor phases half-bridge circuit is used (Fig. 3, a), which allows adjusting the current using 3 modes: “P1”, “P2” and “P0”. The number of the mode corresponds to the number of transistors switched on in the circuit. In the “P2” mode (Fig. 3, b) both transistors VT1 and VT2 are switched on. The path of current passing under the voltage applied to the power source voltage phase  $U_d$  is shown in a dashed line. In the “P0” mode (Fig. 3, d) both transistors are switched off. This

mode is applied for the rapid drop of phase current to the power source (Fig. 3, d, the contour of current drop is shown in a dashed line).

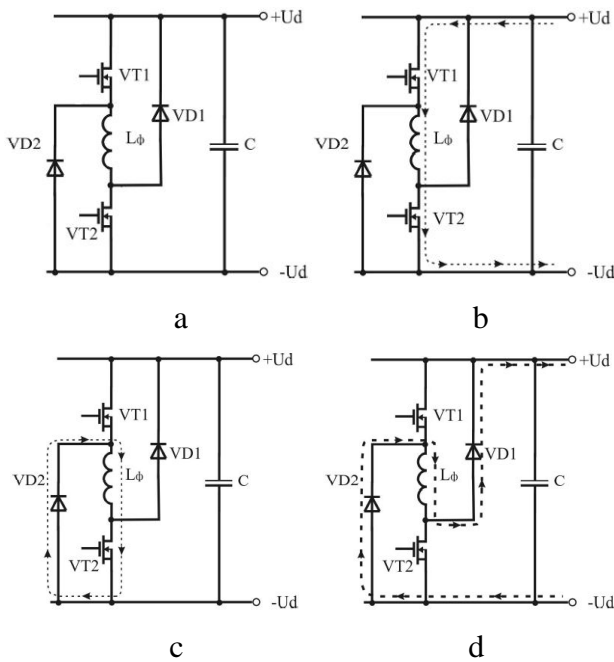

Fig. 3. Circuit of current control (a), and modes of operation of BLDC motor phase at two switched on transistors “P2” (b), one transistor “P1” (c), at both switched off “P0” (d)

In the “P1” mode (Fig. 3, c) only one of the transistors VT1 or VT2 is switched on. As well as the mode “P0” it is applied for the drop of phase current. However, the current induced by EMF of self-induction, is closed through the switched-on transistor VT2 and diode VD2. The difference between the modes “P1” and “P0” consists in the fact that drop of current in the mode “P1” occurs much slower, than in the mode “P0”.

To realize the maximum deceleration rate in the initial area for magnetization of the magnetic system (area 1 in Fig. 2) of BLDC motor the “P2” mode is used. Here the phase current grows rapidly to the required value and the energy from the power source is transferred to BLDC motor and converted into the magnetic field power of the motor. As far as at the area of decreasing magnetic conductivity the polarity of induced EMF of rotation coincides with the polarity of the supplied voltage  $U_d$ , then during passing of phase current in the mode “P2” BLDC motor is switched to deceleration mode using an opposition circuit. The mode “P0” is

used for rapid drop of decelerating phase current at the end of its commutation cycle (area 3 in Fig. 2). At the area 2 (Fig. 2) maintaining of the required phase current is occurred to provide the necessary decelerating intensity of BLDC motor. Here maintaining of current phase is possible in several ways, the most efficient of which is alternation of the modes “P0-P1”. In addition, the mode of dynamic decelerating is replaced by recuperation mode and magnetization of the magnetic system BLDC motor occurs due to the induced electromotive force of rotation in the mode “P1” which eliminates power consumption from the power source [13].

All this allows to achieve not only the significant reduction of deceleration time to 1,2 ms, but also to reduce power consumption on average by 30 % and temperature of BLDC motor surface on average by 20 % as compared to other possible variants of deceleration organizing.

The technical data of the designed BLDC drive are given in Table 1. Exterior view of BLDC drive is shown on Fig.4.

#### 1. Technical data of the designed BLDC drive

Number of poles of stator, $Z_S$	8
Number of poles of rotor, $Z_R$	6
Number of phases, $m$	4
Outer size of stator (mm), $d$	50
Inner diameter of stator (mm), $D_{Si}$	25,5
Air gap (mm), $\delta$	0,13
Number of windings of coil of stator phase, $w_\Phi$	40(30)
Length of stator package (mm), $l_\delta$	30
Inertia moment of rotor ( $\text{kg}\cdot\text{cm}^2$ ) $J_{rot}$	0,0662
Rated voltage (V), $U_{rated}$	24
Deceleration time (ms), $t_{dcl}$	1,2
Maximum deceleration current (A), $I_{dcl}$	3,9
Temperature surface of BLDC electric drive, not more ( $^\circ\text{C}$ ), $T$	65
Minimum rotation frequency ( $\text{min}^{-1}$ ), $n_{min}$	8,48
Maximum rotation frequency ( $\text{min}^{-1}$ ), $n_{max}$	485
Frequency of pulse feed (Hz), $f$	1 – 60

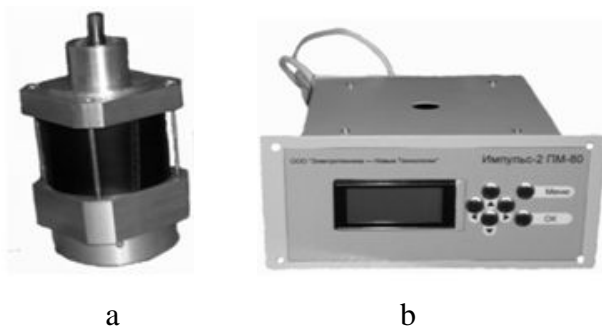

Fig. 4. BLDC drive for PEWF:  
a – BLDC motor; b – control unit

### Conclusions

1. Basing on the analysis of the existing MPEWF drives and considering their drawbacks during tests and industrial operation, the detailed requirements were formulated which must be considered in designing of new MPEWF.

2. Due to a number of obvious advantages of BLDC electric drive, to organize PEWF and reduce inertia of the drive, its weight and size characteristics, the reduction gear is not used in the drive and the torque required for electrode wire feed is released directly from the motor shaft.

3. To achieve the maximum quickresponse, the operation modes of electric circuit of the control unit, responsible for regulating the phase current during decelerating of BLDC motor, were determined, which allowed the achievement of deceleration time of 1,2 ms and also decrease of power consumption on average by 30 %.

### References

1. Dmitriyeiko V.P. Raschet skorosti peremeshcheniya tortsa elektroda pri svarke s mekhanicheskim upravleniyem perenosom [Calculating the Velocity of the Welding Electrode tip with Mechanically Transfer Control], (1979), *Avtomaticheskaya Svarka Publ.*, Kiev, Ukraine, No. 2, pp. 7 – 9 (In Russian).

2. Lebedev V.A., Pichak V.G., and Smolyarko V.V. Mekhanizmy impulsnoy podachi elektrodnoy provoloki s regulirovaniyem parametrov impulsov [Mechanisms of Pulse Feed of Electrode wire with Pulse Parameters Control], (2001), *Avtomaticheskaya Svarka Publ.*, Kiev, Ukraine, No. 5, pp. 31 – 37 (In Russian).

3. Lebedev V.A. Zavisimost mezhdru skorostyami impulsnoy podachi provoloki i yeye plavleniya pri svarke s korotkimi замыkaniyami [The Relationship Between the wire Feed Speed Pulse and its Melting During a Short Circuit Welding], (2007), *Avtomaticheskaya Svarka Publ.*, Kiev, Ukraine, No. 4, pp. 19 – 22 (In Russian).

4. Paton B.Ye., Lebedev V.A, Pichak V.G., Poloskov S.I., and Shchhavelev L.N. Analiz tekhnicheskikh i tekhnologicheskikh vozmozhnostey impulsnoy podachi elektrodnoy provoloki v protsessakh dugovoy svarki i naplavki [Analysis of Technical and Technological Capabilities of Pulsed wire Feed in the Process of arc Welding and Surfacing], (2002), *Svarochnoye Proizvodstvo Publ.*, Moscow, Russian Federation, No. 2, pp. 24 – 31 (In Russian).

5. Voropay N.M. Printsipy postroyeniya ustroystv dlya impulsnoy podachi svarochnoy provoloki [Principles of Construction of Devices for Pulsed wire Feed], (1998), *Avtomaticheskaya Svarka Publ.*, Kiev, Ukraine, No. 8, pp. 19 – 25 (In Russian).

6. Brunov O.G., Fedko V.T., and Slistin A.P. Mekhanizmy impulsnoy podachi svarochnoy provoloki [Mechanisms for Pulsed wire Feed], (1999), *Tekhnologiya Metallov Publ.*, Moscow, Russian Federation, No. 11, pp. 7 – 9 (In Russian).

7. Voropay N.M., Savelyev O.N., and Semergeyev S.S. Elektromagnitnyye mekhanizmy impulsnoy podachi svarochnoy provoloki [Electromagnetic Mechanisms of Pulsed wire Feed], (1980), *Avtomaticheskaya Svarka Publ.*, Kiev, Ukraine, No. 1, pp. 46 – 49 (In Russian).

8. Lebedev V.A. Regulirovaniye skorosti i shaga impulsnoy podachi elektrodnoy provoloki v mekhanizmax na osnove kvazivolnovogo preobrazovatelya [Speed and Step Control of Pulse wire Feed of Mechanisms on the Basis of Quasi-wave Converter], (1996), *Avtomaticheskaya Svarka Publ.*, Kiev, Ukraine, No. 6, pp. 34 – 37 (In Russian).

9. Voropay N.M. Parametry rezhimov i tekhnologicheskiye vozmozhnosti dugovoy svarki s impulsnoy podachey elektrodnoy provoloki [Mode Settings and Technological Possibilities of arc Welding with Pulsed wire Feed], (1966), *Avtomaticheskaya Svarka Publ.*, Kiev, Ukraine, No. 10, pp. 3 – 9 (In Russian).

10. Lebedev V.A., Maksimov S.Yu., Pichak V.G., Rymsha V.V., Radimov I.N., and Gulyy M.V. *Novyye mekhanizmy podachi elektrodnoy i prisadochnoy provolok* [New Feed Mechanisms for Electrode and Filler Wire], (2011), *Svarochnoye Proizvodstvo Publ.*, Moscow, Russian Federation, No. 5, pp. 35 – 39 (In Russian).

11. Bychkov M.G. *Ventilno-induktorny elektroprivod: sovremennoye sostoyaniye i perspektivy razvitiya* [BLDC Electric Drive: Current State and Perspectives of Development], (2007), *Rynok Elektrotekhniki Publ.*, Moscow, Russian Federation, No. 2, pp. 23 – 28 (In Russian).

12. Zakharov A.A. *Perspektivy vnedreniya ventilno-induktornogo elektroprivoda* [Prospects for the Introduction of BLDC Electric-drive], (2008), *Konstruktor. Mashinostroitel Publ.*, St. Petersburg, Russian Federation, No. 5, pp. 6 – 9 (In Russian).

13. Gulyy M.V., Radimov I.N., Rymsha V.V., and Protsyna Z.P. *Tormoznoy rezhim ventilno-reaktivnogo dvigatelya* [Braking Operation of BLDC Electric-Drive], (2009), *Yelektromashinobuduvannya ta Velektroobladnannya Publ.*, Kiev, Ukraine, Vol. 73, pp. 59 – 62 (In Russian).

Received 15.10.2014



Lebedev Vladimir,  
Doctor of Technical Sciences, the E.O.Paton Electric Welding Institute of NAS of Ukraine, Bozhenko, 11. Kiev, Ukraine, 03680,  
E-mail:  
lebedevvladimir@ukr.net



Rymsha Vitaly,  
Doctor of Technical Sciences, Professor, Odessa National Polytechnic University, Institute of Electromechanics and Energy, Department of electrical machines.  
Shevchenko Avenue, 1, Odessa, Ukraine, 65044.  
E-mail:  
rimsha@ukrainemotors.com



Lendel Ivan,  
engineer, the E.O.Paton Electric Welding Institute of NAS of Ukraine.  
Bozhenko, 11. Kiev, Ukraine, 03680.  
E-mail:  
lend\_el@ukr.net